

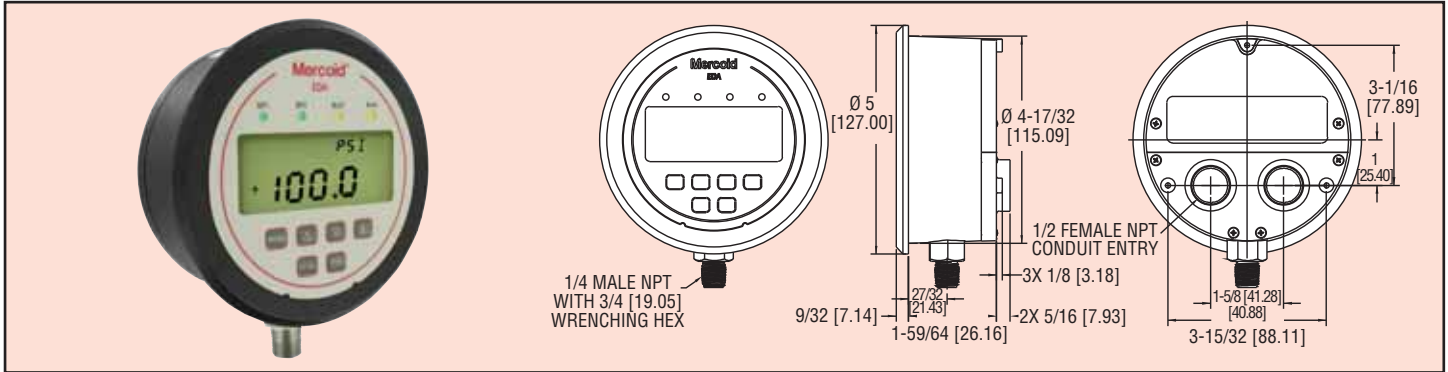

Series
EDA

Electronic Pressure Controller

2 Switches, Indicating Gauge, and Transmitter in One Package



Series EDA Electronic Pressure Control is an extremely versatile compact package that can replace a separate gauge, two switches, and a transmitter in a system saving money, installation time, and panel space. The EDA incorporates two SPDT relays that have the on and off points fully adjustable over the range for control or alarm use. Front face has LED indicators for switch status and a large backlight two-line display showing process value and indication units. Programming is easy with simple menu structure, two-line display, and external programming buttons. Weatherproof housing is ideal for a wide variety of applications with panel mount, flush mount, or pipe mount ability. Features include zero set, adjustable dampening, menu lock out, peak and valley indication, removable terminal blocks, adjustable time delay, and scalable transmitter output.

FEATURES

- **Display Units:** psi, kg/cm², bar, in Hg, ft w.c., kPa, MPa, %FS, in w.c., mbar, cm w.c., mm Hg, or oz/in² (Choices depend on range).
- **Test Mode:** Simulates input over the range without pressuring to easily test switches and transmitter output option.
- **Failsafe:** For sensor failure, over pressure, high temperature limit, low temperature limit, or keypad short. User chooses if relay is de-energized, energized, or no action. With transmitter option, user chooses an output of 3.6 mA 22 mA, or no action.
- **Alternation:** Selectable alternation of set points between the relays for even wear on duplex pump applications.

SPECIFICATIONS

- **Service:** Compatible liquids and gases.
- **Wetted Materials:** 316L SS.
- **Housing:** Glass filled plastic.
- **Accuracy:** $\pm 1\%$ of F.S. including linearity, hysteresis, and repeatability (indicator and transmitter).
- **Stability:** $< \pm 2\%$ of F.S. per year.
- **Pressure Limits:** Ranges up to 6,000 psi: 1.5 x range; 8,000 psi range: 10,000 psi.
- **Temperature Limits:** Ambient: 20 to 140°F (-6.6 to 60°C); Process: 0 to 176°F (-18 to 80°C).
- **Compensated Temperature Limits:** 32 to 122°F (0 to 50°C).
- **Thermal Effect:** $\pm 0.05\%$ of F.S./°F.
- **Display:** 4-digit backlit LCD (Digits: 0.60"H x 0.33" W).
- **Power Requirements:** 12 to 30 VDC/AC.
- **Power Consumption:** 2.5 watts.
- **Electrical Connections:** Removable terminal blocks with two 1/2" female NPT conduit connections.
- **Enclosure Rating:** Meets NEMA 4X (IP65).
- **Warm Up Time:** <10 seconds.
- **Mounting Orientation:** Any position.
- **Weight:** 1.18 lbs (535 g).
- **Agency Approvals:** CE and UL pending.

Example	EDA					EDAW-N1E1-01T0-SST
Series	EDA					Electronic Pressure Controller
Housing		W				Weatherproof
Process Connection			N1			1/4" NPT male bottom
Electrical Connection				E1		Two 1/2" female NPT conduit connections
Range					02 03 04 05 06 07 08 09 10 11 12	0 – 20 psi 0 – 60 psi 0 – 100 psi 0 – 150 psi 0 – 300 psi 0 – 600 psi 0 – 1000 psi 0 – 1500 psi 0 – 3000 psi 0 – 6000 psi 0 – 8000 psi
Transmitter Output					T0 T1 T2 T3 T4 T5	None 4 to 20 mA 1 to 5 VDC 0 to 5 VDC 1 to 6 VDC 0 to 10 VDC
Options					STW NIST 23444	Stainless Steel Tag NIST Certificate Oxygen Cleaning

SWITCH SPECIFICATIONS

- **Switch Type:** 2 SPDT relays.
- **Electrical Rating:** 5 A @ 120/240VAC, 1 A @ 30 VDC.
- **Repeatability:** $\pm 1\%$ of FS (switching only).
- **Set Points:** Adjustable 0-100% of FS.
- **Switch Indication:** External LED for each relay on the front panel.
- **Switch Reset:** Manual or Automatic.

TRANSMITTER SPECIFICATIONS

- **Output Signal:** 4 - 20 mA, 1 - 6 VDC, 1 - 5 VDC, 0 - 5 VDC, or 0 - 10 VDC (Direct or reverse output selection).
- **Minimum Excitation:** 14 VDC.
- **Zero and Span Adjustments:** Menu scalable within the range.

NEW PRODUCT!

