

## Programmable differential pressure controller for measurement, control and supervision of pressure and flow



# MF-PFCA

Mi-215gb / 2003-04-28

### NOTE !

Read the entire instruction before start.

### Application

MicaFlex MF-PFCA is a pressure and flow controller with built in pressure sensor. With the four keys , , **PGM** and **ESC** the desired function is selected as well as setting and scaling. The two-line display clearly indicates the selected function and values.

### Installation

MF-PFCA is designed to be placed on a wall or for recessed mounting through a wall or cabin door. When recessed mounting, a mounting kit, MFM-PANEL is used. The unit is fixed to the wall by four screws, max 4 mm. The location of the holes is shown at the back of the enclosure.

Unscrew the four screws of the front cover and use the bottom screws to attach the front cover on the upper end of the casing, see figure. This makes installation and electrical connection easier. Connect power supply according to the electrical connection.

To each front cover the CPU is mounted, since the I/O calibration of the main circuit board is stored on the CPU-board, it is not possible to move the front cover between different units.

### Output signal

MF-PFCA has two analogue outputs to be used for actual value of pressure and flow, or PI-control output for pressure or flow. VDC or mA output signal must be set by the DIL-switch (DIL1). The same programming must then also be done under "Outputs".

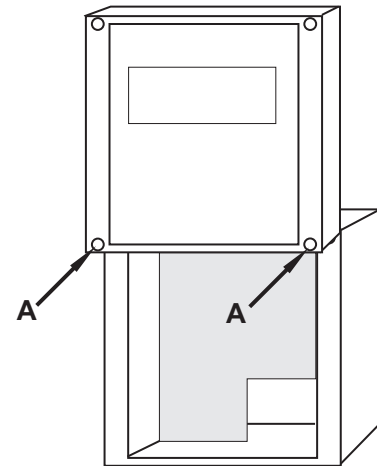





Figure 1, Use the two bottom screws to fix the front cover at the upper edge (A) during installation.

### Basic programming instruction

When the power supply is connected a start menu will be displayed. With the ,  - keys it is possible to scroll through the different start menus. To always have the same start menu, the selection is programmed under "Systems settings". If pressing the **ESC**-key when a different menu is displayed means that the programmed menu is displayed.

### Programming

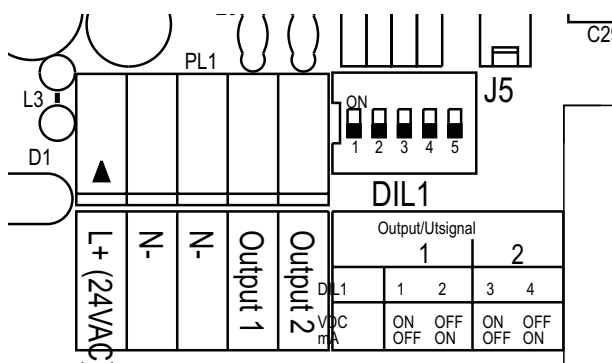

Press the **PGM**-key until the text "PROGRAM-MENU" is displayed. Release the key and the first parameter group is displayed, see list page 2. With ,  it is possible to go through the parameter groups.

1. Current values
2. System settings
3. Outputs
4. Pressure
5. Flow
6. Alarm
7. PI2 controller
8. Communication
9. Internals



DIL 1	1 on, 2 off	volt 1
	3 on, 4 off	volt 2
	1 off, 2 on	mA 1
	3 off, 4 on	mA 2

When the parameter group to be programmed is shown, press **PGM**.

The parameters in that group are then shown, with ,  select the parameter to be programmed and press **PGM** again.

Par.no:	Lead text	Range	Value
<b>Internals</b>			
0	Prog ver	0,00...9,99	
<b>Current values</b>			
100	dP	-32768...32767	
101	Flow	-32768...32767	
102	PI2	0,00...100,00	
103	PI2 CSP	-32768...32767	
105	SPC Input	0,00...100,00	
106	SPD Input	OPEN CLOSED	
107	Mute Input	OPEN CLOSED	
<b>System settings</b>			
4	Display	dP FLOW dP+FLW dP+PI2 FLW+PI2 ALMSTAT	
5	Damping[s]	0,0...9,9	
<b>Outputs</b>			
19	Output 1	dP FLOW PI2	
20	Signal 1	0..10V 2..10V 0..20mA 4..20mA	
21	Output 2	dP FLOW PI2	
22	Signal 2	0..10V 2..10V 0..20mA 4..20mA	
<b>Pressure</b>			
23	MinCal[Pa]	-32768...32767	
24	MaxCal[Pa]	-32768...32767	
25	Unit dP	Pa PaDec mbar iwc	
26	Min range	-32768...32767	
27	Max range	-32768...32767	
28	Min out	-32768...32767	
29	Max out	-32768...32767	
30	Sign dP	POS NEG	
<b>Flow</b>			
31	Unit flow	l/s m3/s m3/h m/s cfm	
32	Max flow	0...32767	
33	Scale flw	0...32767	
34	Set flow	0...32767	
<b>Alarms</b>			
6	Alarm 1	OFF HIGH LOW SP DIFF	
7	Source 1	dP FLOW	

Par.no:	Lead text	Range	Value
8	Level 1	-32768...32767	
9	Delay 1[s]	0...3600	
10	Reset 1	OFF ON	
11	Alarm 2	OFF HIGH LOW SP DIFF	
12	Source 2	dP FLOW	
13	Level 2	-32768...32767	
14	Delay 2[s]	0...3600	
15	Reset 2	OFF ON	
16	Res hold	FOREVER TIMED	
17	Hold [s]	0...3600	
18	Beeper	OFF ALARM 1 ALARM 2 AL1+AL2	
<b>PI2 controller</b>			
35	Source	OFF dP FLOW	
36	Mode	AUTO HAND	
37	Output	DIRECT REVERSE	
53	SP1	-32768...32767	
55	SP2	-32768...32767	
56	SPC Type	OFF 0..10V 2..10V 0..20mA 4..20mA	
57	SPD Mode	OFF SP2 FORCED FROZEN	
58	FORCED	0,00...100,00	
39	NZ [%]	1...50	
40	P-band	0,0...999,9	
41	I-time[s]	0...999	
42	BZ	0...100	
43	I-time BZ	0...999	
<b>Communication</b>			
47	Address	1...247	
48	Location	0...32767	
49	Protocol	COMLI	
50	Baud	600 b 1200 b 2400 b 4800 b 9600 b	
51	Protect	NO YES	

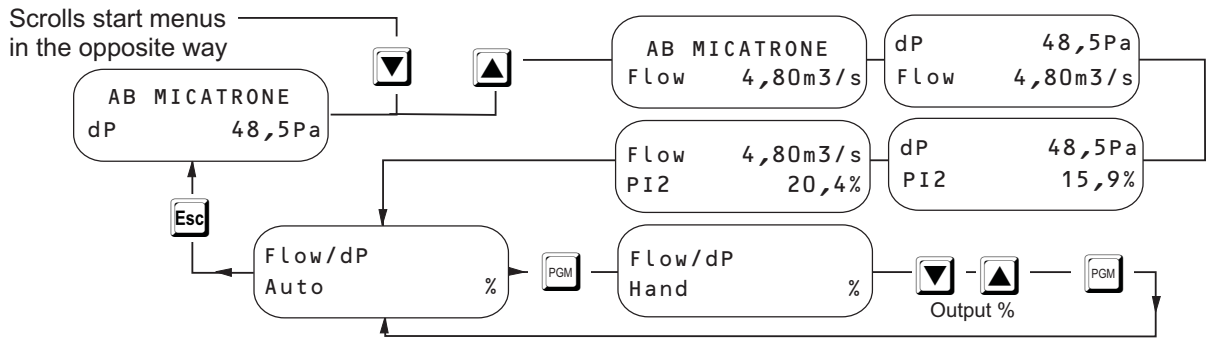

(PGM)

Press key until "PROGRAM-MENU" is displayed.

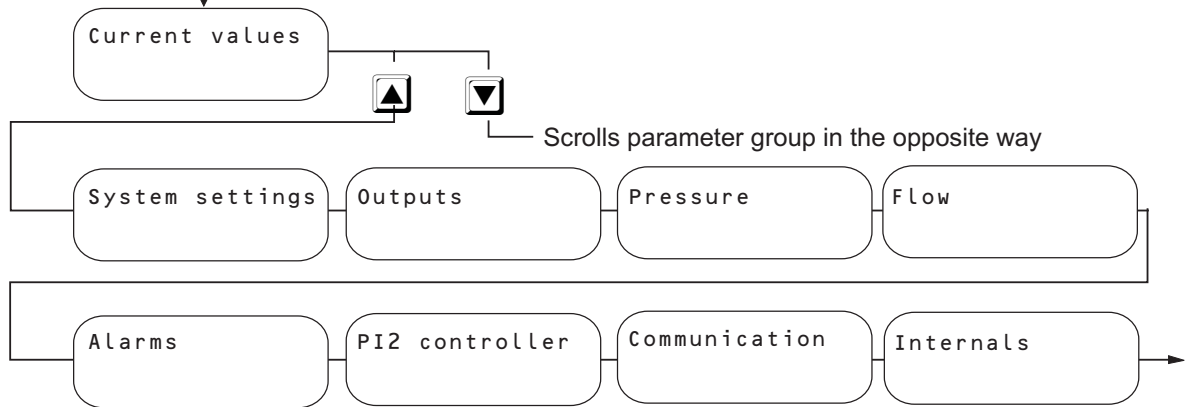

(PGM)

Opens parameter group and allows the parameters to be selected.

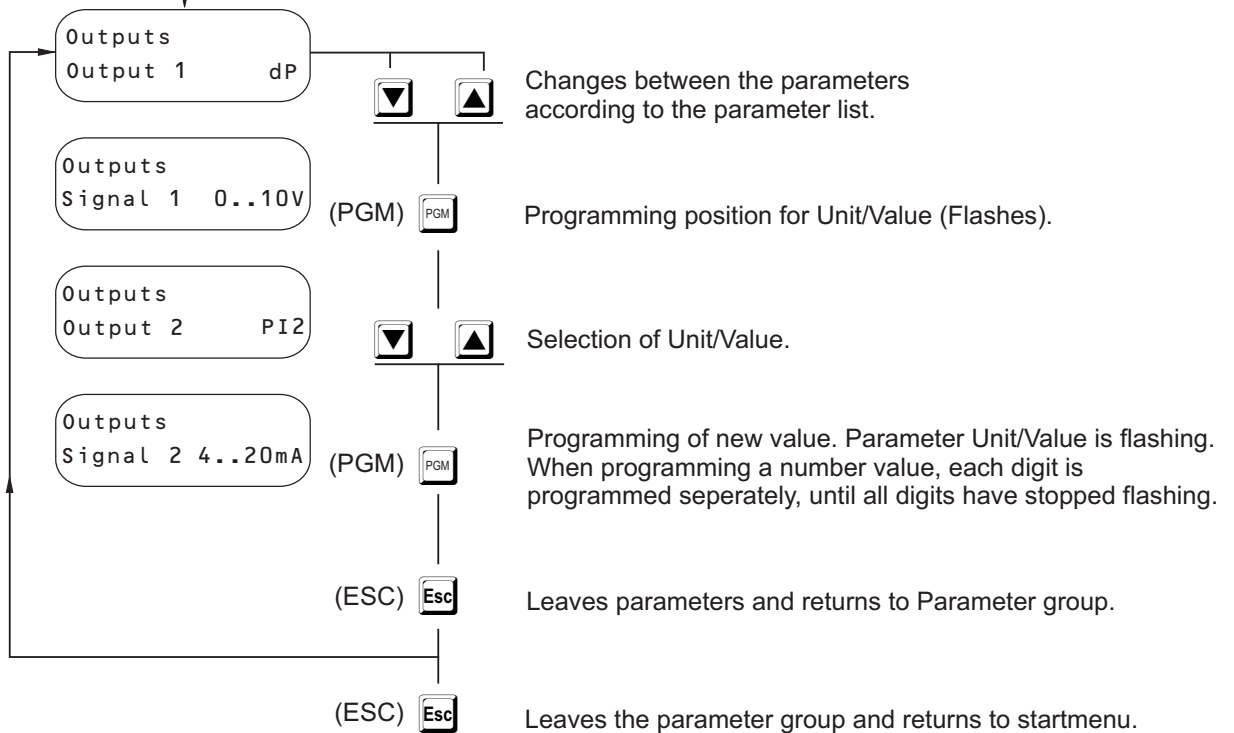

## Digit programming

Every digit is separately programmed. Press **▲** for 1...9 after 9 if negative values are accepted -9...0. Digit to be changed is flashing. When all digits are programmed press **PGM** and the whole row will flash. To stop incorrect programming press **ESC** and then **PGM** to execute new programming.

## Unit or value programming

Press **▼▲** to change unit/value. When selected press **PGM** then the whole row will flash.

Press **ESC** to return to parameter group.

Press **ESC** to leave the parameter group and return to the start menu.

**NOTE !** It is always possible to stop an incorrect programming with **ESC** if you have not pressed **PGM** after the last digit or unit/value selection.

## Programming instruction

We recommend you to follow this instruction.

When any of the start menus are displayed press **PGM** until "PROGRAM-MENU" is displayed.

### 1. Current values

Current values		
100	dP	-32768...32767
101	Flow	-32768...32767
102	PI2	0,00...100,00
103	PI2 CSP	-32768...32767
105	SPC Input	0,00...100,00
106	SPD Input	OPEN CLOSED
107	Mute Input	OPEN CLOSED

Shows the actual values.

### 2. System settings

System settings		
4	Display	dP FLOW dP+FLW dP+PI2 FLW+PI2 ALMSTAT
5	Damping[s]	0,0...9,9

Select the start menu to be shown. Select the time constant (damping) for the flow and pressure measurement 0...9,9 seconds, normally 1...3 seconds.

### 3. Outputs

Outputs		
19	Output 1	dP FLOW PI2
20	Signal 1	0..10V 2..10V 0..20mA 4..20mA
21	Output 2	dP FLOW PI2

22	Signal 2	0..10V 2..10V 0..20mA 4..20mA
----	----------	--

Select the sources for the two analogue outputs.

The selection is possible between actual value of pressure or flow, PI-control output for pressure or flow.

**NOTE !** There is only one controller in the unit. The source for the PI-controller is programmed under "PI2 controller".

**NOTE !** Always have the same source, pressure or flow, for the actual output and PI-control output. To measure and control flow or velocity it is necessary to connect the unit to a flow measurement device mounted in the duct or fan inlet etc.

Select the output signal for the two outputs 0/2...10 VDC or 0/4...20 mA.

**NOTE !** The DIL-switch on the circuit board for VDC or mA output must be set the same as the programmed output signal.

It is possible to have VDC on one of the output and mA on the other.

### Pressure

Pressure		
23	MinCal[Pa]	-32768...32767
24	MaxCal[Pa]	-32768...32767
25	Unit dP	Pa PaDec mbar iwc
26	Min range	-32768...32767
27	Max range	-32768...32767
28	Min out	-32768...32767
29	Max out	-32768...32767
30	Sign dP	POS NEG

**NOTE !** If the unit is used for flow measurement, you do not need to do any programming under "Pressure".

Micaflex PFCA is factory calibrated to a special range. The range is marked on the label on the right side of the casing. The calibration is always in Pa. Under "Pressure" you also find the calibrated range, 'Min cal' and 'Max cal'. These values are only notes and are not possible to change. If you want to change to another unit, program the "Unit dP". Selections: Pa, Pa Dec (Pa with decimal), mbar or iwc (inch water). When programming a new unit the actual range is shown under 'Min range' and 'Max range'. These values are only notes and not possible to change. To change the range in selected unit or factory programmed unit, program 'Min output' and 'Max output'. The programmed values shall always be in the selected unit (Pa, Pa,dec, mbar, iwc). When scaling, note that the accuracy always is in % of the factory scaled range.

**Negative character dP**

When measuring a negative pressure normally the MF-PFCA will show the same as measuring a positive pressure (no sign). When programming 'Sign dP' to NEG (negative) you have a negative (-) sign in front of the actual value.

**5. Flow**

Flow			
31	Unit flow		l/s m <sup>3</sup> /s m <sup>3</sup> /h m/s cfm
32	Max flow	0...32767	
33	Scale flw	0...32767	
34	Set flow	0...32767	

If you have programmed the MF-PFCA for flow follow this instruction.

Program the unit for flow to: l/s, m<sup>3</sup>/s, m<sup>3</sup>/h, m/s or cfm (cubic feet per minute).

The basic flow calculation used is made with  $\sqrt{dP}$ . To have the display and the output corresponding to the actual flow or velocity in the selected unit it is necessary to make some calculations.

Different manufactors of flow measurement devices have different calculation, but common for all is  $\sqrt{dP}$ . Use the actual formula to calculate the max flow for the factory calibrated measure range. The calculated flow or velocity is then programmed under 'Max flow' in the selected unit. It is possible to scale the flow range under 'Scale flow'.

**NOTE !** If no scaling is done the same value as in 'Max flow' must be programmed into 'Scale flw'. When scaling the flow note that the accuracy depends on the 'Max flow' range.

If adjustment of the displayed actual flow or velocity must be done, it is possible to do under 'Set flow'. Programme the actual flow from a reference flow sensor or equal.

**NOTE !** The programming must be done at the same time as the reference values are presented. Automatically the 'Max flow' programming will be changed for the new values. If the unit is connected to a BMS system or equal, the 'Max flow' or if scaled, the 'Scale flw' and the output signal must be programmed in the connecting system.  
Eg 3,5 m<sup>3</sup>/s = 10 VDC. The output signal is linear to the flow or velocity.

**Alarms**

Alarms			
6	Alarm 1		OFF HIGH LOW SP DIFF
7	Source 1		dP FLOW
8	Level 1	-32768...32767	
9	Delay 1[s]	0...3600	
10	Reset 1		OFF ON

11	Alarm 2		OFF HIGH LOW SP DIFF
12	Source 2		dP FLOW
13	Level 2	-32768...32767	
14	Delay 2[s]	0...3600	
15	Reset 2		OFF ON
16	Res hold		FOREVER TIMED
17	Hold [s]	0...3600	
18	Beeper		OFF ALARM 1 ALARM 2 AL1+AL2

MicaFlex PFCA includes an alarm function with two separate alarms, 'Alarm 1' / 'Alarm 2', with alarm function for high (HIGH), low (LOW) or set point difference (SP DIFF).

Settings for the break point 'Level 1' and 'Level 2', with separate time delays, 'Delay 1' and 'Delay 2'. When selecting SP DIFF the difference between the set point value and the actual value is monitored. This function may be used when the PFCA is using a floating set point for instance in balanced flow control. Both alarms can be selected to monitor the differential pressure or flow/velocity, 'Source 1' and 'Source 2'. Each alarm has its own alarm relay with potential free output selectable for either normally open (NO) or normally closed (NC). The built-in buzzer can be programmed under 'Beeper' to sound when alarm occur.

In normal operation the green LED on the front cover is lit. When passing the alarm limit the red LED will lit and after the programmed delay the LED starts flashing and the alarm relay output will shift to alarm state. If the buzzer is programmed for the current alarm it will sound.

By pressing the **ESC** (Reset) button on the front cover the buzzer is silenced when an alarm occurs. The Reset function for the alarm relays can be programmed individually for each alarm. If the parameter 'Reset 1' and/or 'Reset 2' is set to ON, the selected alarm relay will also be reset and the alarm output will shift to normal state. Reset can also be done externally by short circuiting terminal 11 and 12.

Resetting of an alarm condition, 'Res Hold', can be programmed to last FOREVER or to last for a specified time TIMED. The time is programmed under 'Hold [s]'. The TIMED-function will keep the alarm reset during a specified time, when the time has elapsed the buzzer will sound again and the alarm relay output will shift to alarm state if an alarm condition exists. By using the FOREVER-function the alarm is reset for as long as the current alarm condition exists.

The alarm function, both buzzer and alarm relay output, can be checked in normal operating mode by pressing the **ESC** (Test) key on the front cover. When testing the buzzer it must be programmed to

sound under 'Beeper' otherwise no sound will be heard. When testing alarm relay output, 'Reset 1' and/or 'Reset 2' must be programmed ON for the alarm relay output to shift.

In programming mode the alarm functions are blocked and the green LED is lit on the front cover.

## 8. PI2 controller

PI2 controller			
35	Source	OFF dP FLOW	
36	Mode	AUTO HAND	
37	Output	DIRECT REVERSE	
53	SP1	-32768...32767	
55	SP2	-32768...32767	
56	SPC Type	OFF 0..10V 2..10V 0..20mA 4..20mA	
57	SPD Mode	OFF SP2 FORCED FROZEN	
58	FORCED	0,00...100,00	
39	NZ [%]	1...50	
40	P-band	0,0...999,9	
41	I-time[s]	0...999	
42	BZ	0...100	
43	I-time BZ	0...999	

MF-PFCA has a PI-controller specially developed for pressure or flow control. The controller has an analogue input SPC for Volt/mA and a digital input SPD which is activated by a potential free contact closing. SPC and SPD function may be used together. At closed contact the SPD function gets priority.

### SPC

SPC function is used when an external Volt/mA signal shall change the set point. The set point continuously changes between two selected limits/set points SP1 and SP2. Selection between volt/mA is made with DIL-switch no 2, and is programmed with 'SPC Type' to 0/2...10 VDC / 0/4...20 mA or 'OFF'.

### SPD

SPD function is activated by a potential free closing contact. SPD function may change between two set points SP1 and SP2 or force the output to a set value before e.g. start of a fan. Under 'SPD Mode' the selection SP2 is made if a change between two set points is desired, FORCED if forced operation is desired, FROZEN if the actual control output signal should be frozen or OFF if SPD function is not wanted. If the function FORCED is selected, the wanted control output 0...100 % when the contact is closed is programmed under FORCED.

The controller may be programmed as a standard PI-controller, but in most pressure or flow applica-

tions we recommend that it is programmed as an I-controller without P-band. When it is programmed as an I-controller there are two programmable I-times. E.g. Outside a desired level on both sides of the set value it is possible to have a shorter I-time and inside a longer I-time.

### Programming

Select source: dP, FLOW OFF.

Select mode: AUTO, HAND

Normally AUTO

The output signal is programmed to be DIRECT or REVERSE .

Normally REVERSE (if the pressure or flow is higher than the set point the output signal will decrease). Programme the set point in the earlier programmed unit for dP or Flow. Programme the neutral zone 'NZ' to 0...9,9% of the selected pressure or flow range, normally 1...5%. If the range is not scaled the 'NZ' is in % of the factory calibrated pressure range or max flow range. If scaled in % of the scaled range, half of the neutral zone is on each side of the set point.

### P-band

Normally not used for pressure and flow control.

### I-time

When programming as an I-controller there are two possibilities:

1. The same I-time over the whole range. Normally used.  
Programme 'BZ' to 000 and 'I-time BZ' to 000. The I-time should normally be longer than the time for the damper motor etc to go from min to max.

### 2. Shifting between two I-times

If working with two I-times the reason is often that outside a set pressure or flow limit you want to have a fast response and inside a shorter response (see figure above).

BZ: limit for switching I-time.

BZ is in % of the scaled pressure or flow range, if not scaled % of the factory calibrated pressure range or max flow range.

Half the BZ is on each side of the set point.

If the control output is not going to a stable position increase the I-time.

If the effect is not efficient enough, increase the neutral zone.

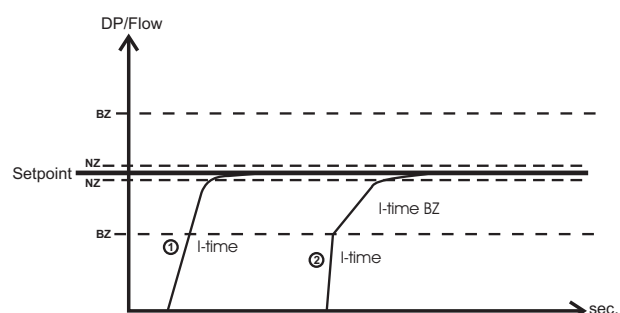

Hand position

Return to start menu and select this menu.

Flow / dP  
Auto %

Press **PGM**. "AUTO" will shift to "HAND" and make it possible to set the output in % with the -keys .  
To return to "AUTO" press **PGM**.  
To return to the start menu press **ESC**.

**Zero set of the pressure sensor**

Disconnect the pressure tubes or set the manifold valve in the calibration position.  
With the startmenu displayed, press simultaneously both the keys until the display shows:

ZERO OFFSET

Release the keys when the display shows:

ZERO OFFSET  
ADJUSTING

When zero set is ready, the unit displays

ZERO OFFSET DONE

and automatically returns to start menu.

**Technical Data**

Indicator,	Alphanumeric LCD, 2 rows, 2x16 characters
Measurement range of;	
-Pressure:	see label
-Flow:	0...30.000
Accuracy:	± 0,5 %
Temperature dependence:	± 0,5 % /10 °C
Time delay:	0...9,9 sec.
Outputs:	Two analogue outputs 0/2...10 VDC, 0/4...20 mA selectable and scalable SPD potential free closing SPC 0/2...10 VDC, 0/4...20 mA
Inputs:	
Ambient temperature:	0...50 °C
Alarm (visible):	Two separate alarms, high&low Red LED alarm indication
Power supply:	24 VAC ±15 % 20...32 VDC
Power consumption:	3 VA
Housing class.:	IP 65
Electric connection,	
- rigid wire :	1 x 2.5mm <sup>2</sup> / terminal
- flexible wire :	1 x 1.5mm <sup>2</sup> / terminal
Cable entry:	3 threaded holes M16x1,5 (cable connectors not attached)
Pressure conn.	Pneumatic tube 8/6mm [D <sub>o</sub> /D <sub>i</sub> ]
Dimensions:	WxHxD 122 x 120 x 87mm
Conformity:	EMC SS-EN 50081-1 SS-EN 50082-2 LVD SS-EN 61010-1

**Service**

Check the zero point every 6 months.

**Electrical connection:**

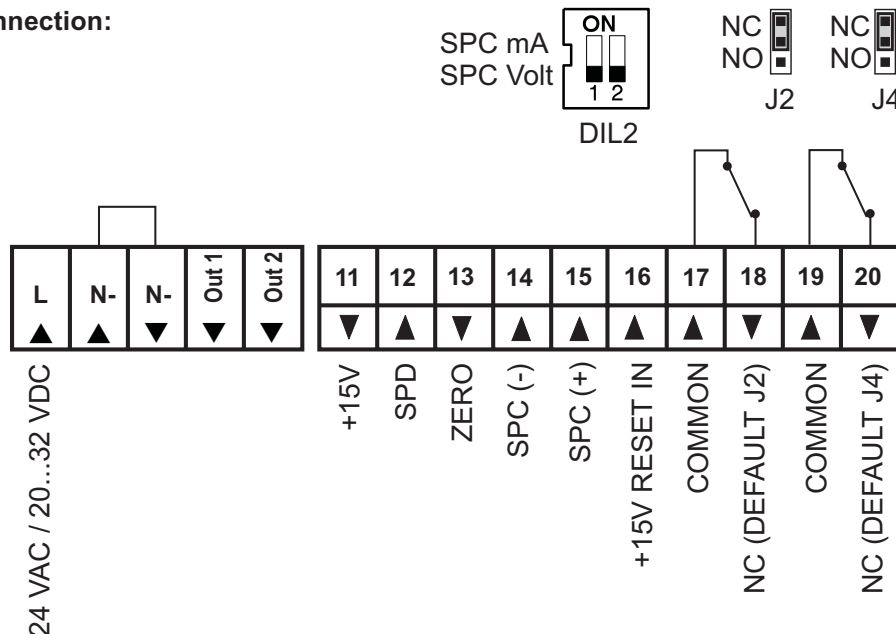

**AB MICATRONE**  
Dalvägen 8  
SE-169 56 SOLNA  
SWEDEN

**Telephone:** +46 8-470 25 00  
**Fax:** +46 8-83 27 80  
**Internet:** [www.micatrone.se](http://www.micatrone.se)  
**E-mail:** [info@micatrone.se](mailto:info@micatrone.se)