

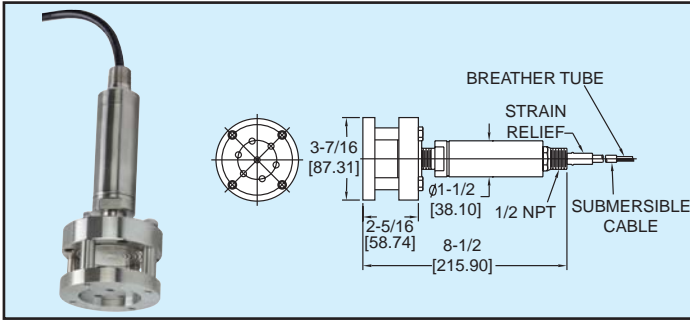

Series
PBLT

Submersible Level Transmitter

Perfect for Sludge and Slurries, Lightning Protected



PBLT Submersible Level Transmitter is manufactured for years of trouble free service in the harshest applications. The PBLT measures the height of liquid above it's position in the tank referenced to atmospheric pressure. The transmitter consists of a bonded foil, strain gauge, sensing element, encased in a 316 SS housing. Perfect for wastewater and slurry applications with features to protect the unit from these demanding applications. Superior lightning and surge protection utilizing dual arrester technology, grounded to case, eliminating both power supply surges and lightning ground strike transients. Large diameter 316 SS diaphragm seal is non-clogging and damage resistant to floating solids.

Comes equipped with a 220-pound tensile strength, shielded, vented, Tefzel cable. Ventilation tube in the cable automatically compensates for changes in atmospheric pressure above the tank. The vent is protected with a filter eliminating moisture collection in the transducer.

APPLICATIONS

- Wastewater: sludge pits, clarifiers, digesters; Alum tanks; Chemical storage tanks; Oil tanks; Lime slurry; Sumps; Reservoirs

SPECIFICATIONS

Service: Compatible liquids.
Wetted Materials: 316 SS and 15-5 SS, Cable: Tefzel.
Accuracy: $\pm 0.25\%$ of full scale.
Temperature Limits: -20 to 190°F (-28.9 to 87.8°C).
Compensated Temperature Range: 0 to 180°F (-17.8 to 82.2°C).
Pressure Limit: 2X full scale range.
Thermal Effect: Less than $\pm 2.0\%$ of full scale per 100°F.
Power Requirement: 9 to 36 VDC.
Output Signal: 4 to 20 mA DC, two wire.
Response Time: < 5 ms.
Loop Resistance: 75 ohms at 24 VDC.
Electrical Connections: Wire pigtail.
Enclosure Rating: Intrinsically safe with proper barrier.
Mounting Orientation: Suspended in tank below level being measured. Can be placed on the bottom of the tank on its side.
Weight: 8.8 lb (4.0 kg).
Standard Features: Calibration certificate.
Electrical Protection: Dual transient lightning and surge arrestors exceeding FM approved I/S and meet EMI/RFI standards Mil-STD 461/462 and ground to transducer case.

STOCKED MODELS in bold

Model Number	Pressure Range	Cable Length
PBLT-5-40	5 psi (.35 bar)	40 feet (12.2 m)
PBLT-10-40	10 psi (.69 bar)	40 feet (12.2 m)
PBLT-15-60	15 psi (1.03 bar)	60 feet (18.3 m)
PBLT-20-60	20 psi (1.39 bar)	60 feet (18.3 m)

Extended cable length available contact the factory.

Level



Series
SBLT

Submersible Level Transmitter

Perfect for Ground Water and Wells, Lightning Protected

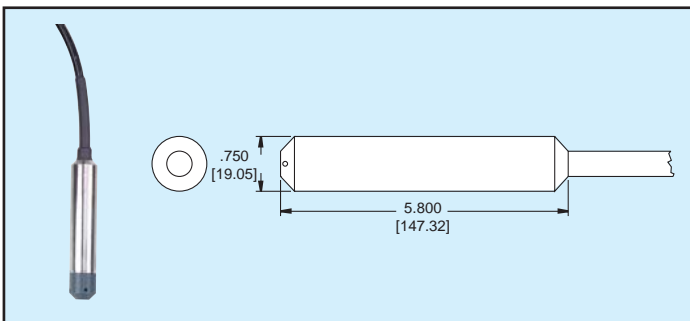

SBLT Submersible Level Transmitter is manufactured for years of trouble free service. The transmitter consists of a bonded foil, strain gauge, sensing element, encased in 316 SS housing. Superior lightning and surge protection utilizing dual arrester technology, grounded to case, eliminating both power supply surges and lightning ground strike transients. Bullet nose design protects diaphragm from damage. Comes equipped with a 220-pound tensile strength, shielded, vented, Polyurethane cable. Ventilation tube in the cable automatically compensates for changes in atmospheric pressure above the tank. The vent is protected with a filter eliminating moisture collection in the transducer.

APPLICATIONS

- Well monitoring; Ground water monitoring; Environmental remediation; Surface water monitoring; Down hole; Water Tanks

SPECIFICATIONS

Service: Compatible liquids.
Wetted Materials: Body: 316 SS, Cable: Polyurethane. Bullet Nose: PVC.
Accuracy: $\pm 0.20\%$ of full scale.
Temperature Limits: -40 to 150° F (-40 to 65.6° C).
Compensated Temperature Range: 0 to 140°F (-17.8 to 60°C).
Pressure Limit: 1.5X full scale range.
Thermal Effect: Less than $\pm 2.0\%$ of full scale per 100°F.
Power Requirement: 9 to 36 VDC.
Output Signal: 4 to 20 mA DC, two wire.
Response Time: < 5 ms.
Loop Resistance: 750 ohms at 24 VDC
Electrical Connections: Wire pigtail.
Mounting Orientation: Suspended in tank below level being measured. Can be placed on the bottom of the tank on its side.
Standard Features: Calibration certificate.
Weight: 3.5 lb (1.59 kg).
Electrical Protection: Dual transient lightning and surge arrestors exceeding FM approved I/S and meet EMA/RFI standards Mil-Std 461/462 and ground to transducer case.

STOCKED MODELS in bold

Model Number	Pressure Range	Cable Length
SBLT-5-40	5 psi (.35 bar)	40 feet (12.2 m)
SBLT-10-40	10 psi (.69 bar)	40 feet (12.2 m)
SBLT-15-60	15 psi (1.03 bar)	60 feet (18.3 m)
SBLT-20-60	20 psi (1.39 bar)	60 feet (18.3 m)

Extended cable length available contact the factory.