



Series SAV-BT

# Angle Seat Valve - Bronze NPT

Low Cost, Compact Design, For Use with Gases and Liquids



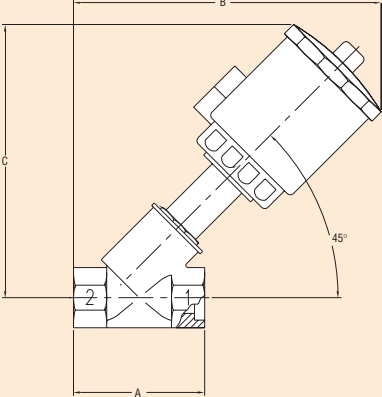

DIMENSIONS					
Port Connection	A	B	C	Actuator Diameter	Cv
1/2 NPT	2-9/16	5-43/64	4-7/8	1-3/4"	4.7
1/2 NPT	2-9/16	7-9/16	6-47/64	2-1/2"	4.7
3/4 NPT	2-61/64	6-7/64	4-31/32	1-3/4"	8.8
3/4 NPT	2-61/64	7-51/64	6-15/16	2-1/2"	8.8
1 NPT	3-35/64	6-39/64	6-47/64	1-3/4"	19.6
1 NPT	3-35/64	8-23/64	7-19/64	2-1/2"	19.6
1 NPT	3-35/64	8-25/32	7-23/32	3-9/16"	19.6
1-1/4 NPT	4-11/32	8-55/64	7-39/64	2-1/2"	29.4
1-1/4 NPT	4-11/32	9-7/32	4-61/64	3-9/16"	29.4
1-1/2 NPT	4-47/64	9-1/16	7-51/64	2-1/2"	45.5
1-1/2 NPT	4-47/64	9-27/64	8-5/32	3-9/16"	45.5
2 NPT	5-29/32	9-49/64	8-5/32	2-1/2"	57.8
2 NPT	5-29/32	10-1/8	8-33/64	3-9/16"	57.8

**Save space while maintaining flow rates** with the compact Series SAV-BT Angle Seat Valve. The pneumatic, externally piloted angle seat valve is operated by a single acting actuator with a mechanical spring for failsafe operation. Select from either normally closed (NC) or normally open (NO) configurations. Bi-directional valves (normally closed) are designed for special applications that require flow in both directions and incorporate an anti-waterhammer design for liquid applications flowing under the seat. Normally open valves can also be used to prevent waterhammer on valve closure in liquid applications.

Constructed of bronze, 316 Stainless Steel, and Teflon® seals, the Series SAV-BT can be used in most gas, liquid, and steam applications. Integral heat sinks dissipate heat protecting the Polyamide actuator, ensuring longer life.

The Series SAV-BT can be mounted in any position. For added flexibility, the actuator housing rotates 360 degrees for positioning of the pressure ports. Standard visual indicator shows open or closed position.

### SPECIFICATIONS

#### VALVE BODY

**Service:** Gases and liquids compatible with wetted materials.

#### Wetted Materials:

- Valve Body: Bronze.
- Plug and stem: AISI 316L Stainless Steel.
- Stem O-ring: Viton®.
- Seat and seal: PTFE.

**Line Sizes:** 1/2" to 2" NPT.

**Pressure Limits:** See table below.

**Flow Leakage:** Meets ANSI Class VI.

**Temperature Limits:** 14 to 356°F (-10 to 180°C).

#### ACTUATOR

**Type:** Piston/pneumatic spring.

**Pilot Connections:** 1-3/4" dia. act.: 1/8" BSP; 2-1/2" dia. act.: 1/4" BSP; 3-9/16" dia. act.: 1/4" BSP.

**Pilot Media:** Air, water, inert gas.

**Pressure Limits:** See table below.

**Temperature Limit:** 140°F (60°C).

### STOCKED MODELS in bold

Port Connection	Actuator Diameter	Normally Closed	Normally Open	Bi-directional (NC)
1/2 NPT	1-3/4"	<b>SAV-BTA1-NC</b>	SAV-BTA1-NO	SAV-BTA1-BD
1/2 NPT	2-1/2"	<b>SAV-BTA2-NC</b>	SAV-BTA2-NO	SAV-BTA2-BD
3/4 NPT	1-3/4"	SAV-BTB1-NC	SAV-BTB1-NO	SAV-BTB1-BD
3/4 NPT	2-1/2"	<b>SAV-BTB2-NC</b>	SAV-BTB2-NO	SAV-BTB2-BD
1 NPT	1-3/4"	SAV-BTC1-NC	SAV-BTC1-NO	SAV-BTC1-BD
1 NPT	2-1/2"	<b>SAV-BTC2-NC</b>	SAV-BTC2-NO	SAV-BTC2-BD
1 NPT	3-9/16"	SAV-BTC3-NC	SAV-BTC3-NO	SAV-BTC3-BD
1-1/4 NPT	2-1/2"	SAV-BTD2-NC	SAV-BTD2-NO	SAV-BTD2-BD
1-1/4 NPT	3-9/16"	SAV-BTD3-NC	SAV-BTD3-NO	SAV-BTD3-BD
1-1/2 NPT	2-1/2"	SAV-BTE2-NC	SAV-BTE2-NO	SAV-BTE2-BD
1-1/2 NPT	3-9/16"	SAV-BTE3-NC	SAV-BTE3-NO	SAV-BTE3-BD
2 NPT	2-1/2"	SAV-BTF2-NC	SAV-BTF2-NO	SAV-BTF2-BD
2 NPT	3-9/16"	SAV-BTF3-NC	SAV-BTF3-NO	SAV-BTF3-BD

#### Accessories

**A-538 1/8" BSP to 1/8" NPT adapter**, for 1-3/4" dia. actuators.

**A-539 1/4" BSP to 1/4" NPT adapter**, for 2-1/2", 3-9/16" dia. actuators.

Viton® and Teflon® are registered trademarks of E.I. du Pont de Nemours and Company.

### LINE AND PILOT PRESSURE CHART (psi)

Port Connection	Actuator Diameter	Normally Closed					Normally Open					Bi-Directional (Normally Closed)				
		Max. Line Pres.	Max. Steam Pres.	Flow Direction	Min. Pilot Pres.	Max. Pilot Pres.	Max. Line Pres.	Max. Steam Pres.	Flow Direction	Min. Pilot Pres.	Max. Pilot Pres.	Max. Line Pres.	Max. Steam Pres.	Flow Direction	Min. Pilot Pres.	Max. Pilot Pres.
1/2 NPT	1-3/4"	230	130	Overseat	26	150	230	130	Underseat	26	150	230/230	130/130	Ovr/Undr	73	150
1/2 NPT	2-1/2"	290	130	Overseat	22	150	230	130	Underseat	22	150	230/230	130/130	Ovr/Undr	55	150
3/4 NPT	1-3/4"	230	130	Overseat	26	150	230	130	Underseat	26	150	230/100	130/100	Ovr/Undr	73	150
3/4 NPT	2-1/2"	290	130	Overseat	22	150	230	130	Underseat	22	150	230/230	130/130	Ovr/Undr	55	150
1 NPT	1-3/4"	230	130	Overseat	26	150	230	130	Underseat	26	150	230/75	130/75	Ovr/Undr	73	150
1 NPT	2-1/2"	290	130	Overseat	22	150	230	130	Underseat	22	150	230/160	130/130	Ovr/Undr	55	150
1 NPT	3-9/16"	290	130	Overseat	15	120	230	130	Underseat	15	115	230/200	130/130	Ovr/Undr	48	115
1-1/4 NPT	2-1/2"	230	130	Overseat	44	150	230	130	Underseat	22	150	230/90	130/90	Ovr/Undr	55	150
1-1/4 NPT	3-9/16"	230	130	Overseat	36	120	230	130	Underseat	15	115	230/175	130/130	Ovr/Undr	48	115
1-1/2 NPT	2-1/2"	230	130	Overseat	44	150	230	130	Underseat	22	150	175/60	130/60	Ovr/Undr	55	150
1-1/2 NPT	3-9/16"	230	130	Overseat	36	120	230	130	Underseat	15	115	230/115	130/115	Ovr/Undr	48	115
2 NPT	2-1/2"	160	130	Overseat	44	150	175	130	Underseat	22	116	115/36	115/36	Ovr/Undr	55	150
2 NPT	3-9/16"	220	130	Overseat	36	120	230	130	Underseat	15	115	200/75	130/75	Ovr/Undr	48	115

New Products New Products New Products New Products